

Rod Replacement Instructions

For Omni-Pro .75" / 1" / 1.2" / 1.5" Pitch

For Omni-Grid™ 360^{WELD} 3/4" / 1" / 1 1/2" Pitch



Tools

Ruler



Straight Edge, Square or Triangle

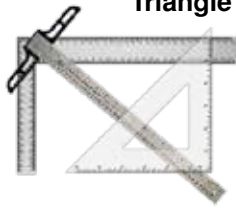

Grinder



Chain Break



Bolt Cutters



Replacement Rods



TIG Welder



Welding Mask



Safety Goggles



Reamer Tool



Gloves



Questions? Call 540-662-3494

Removing a Rod:

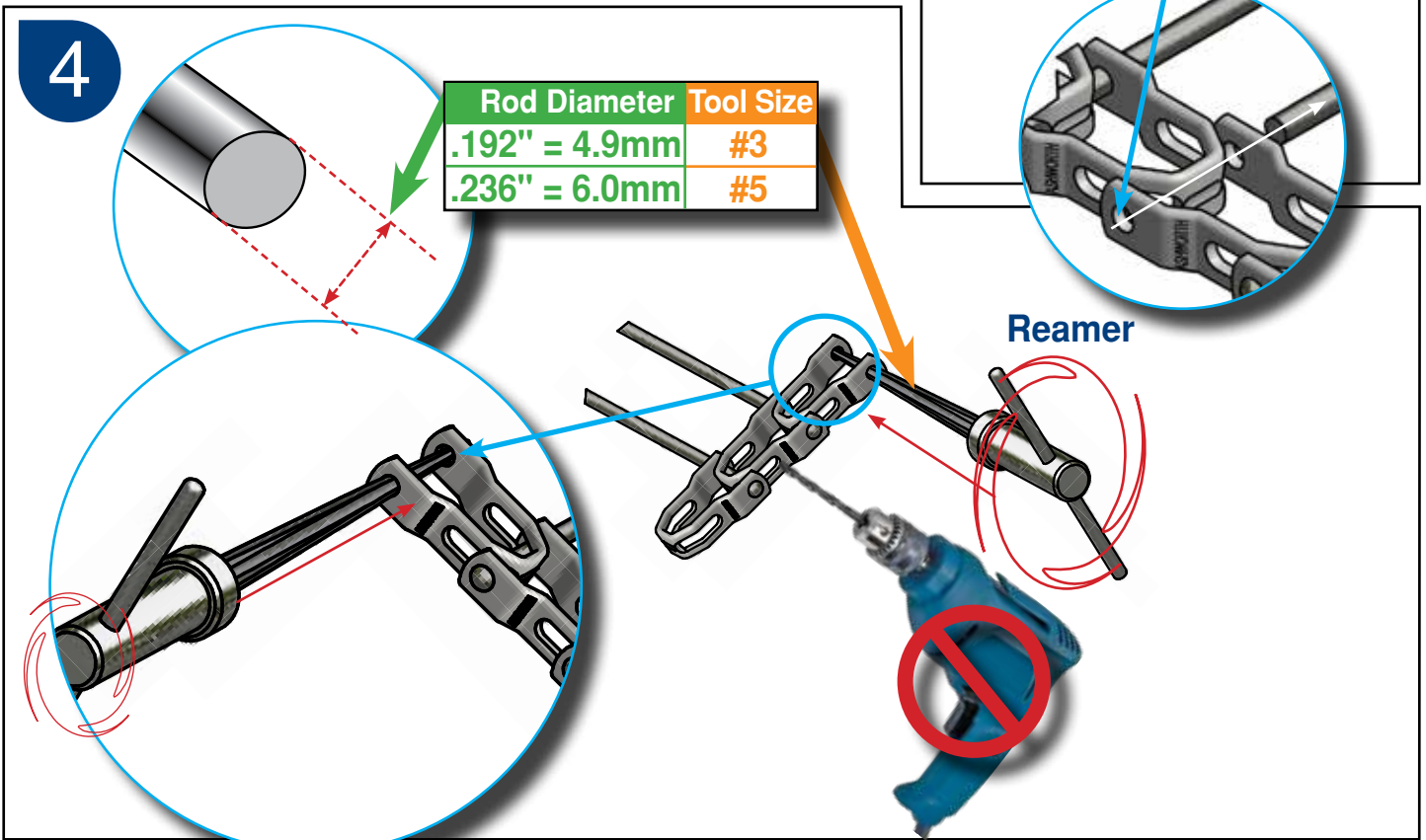
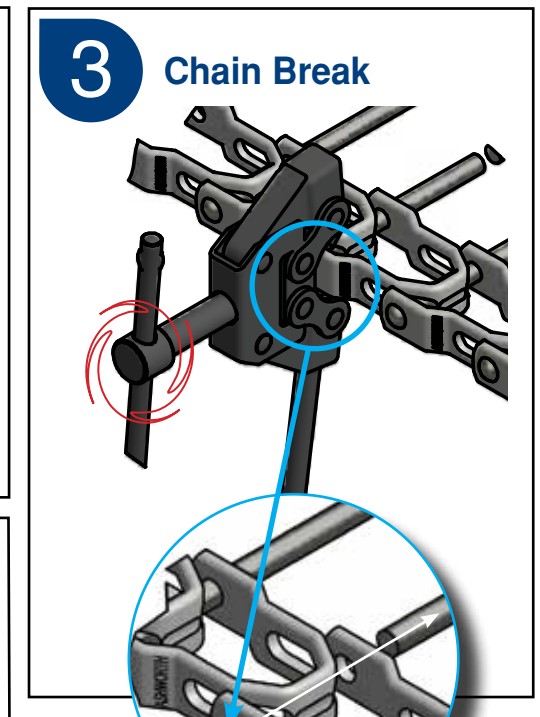
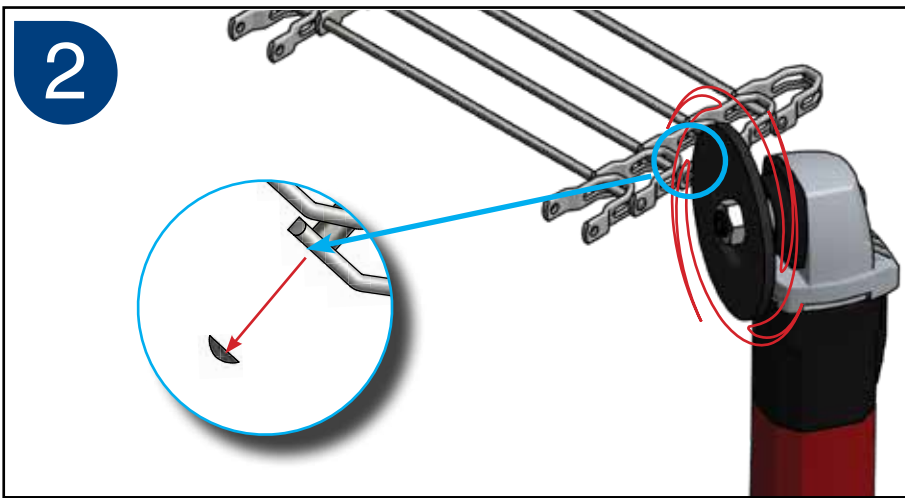
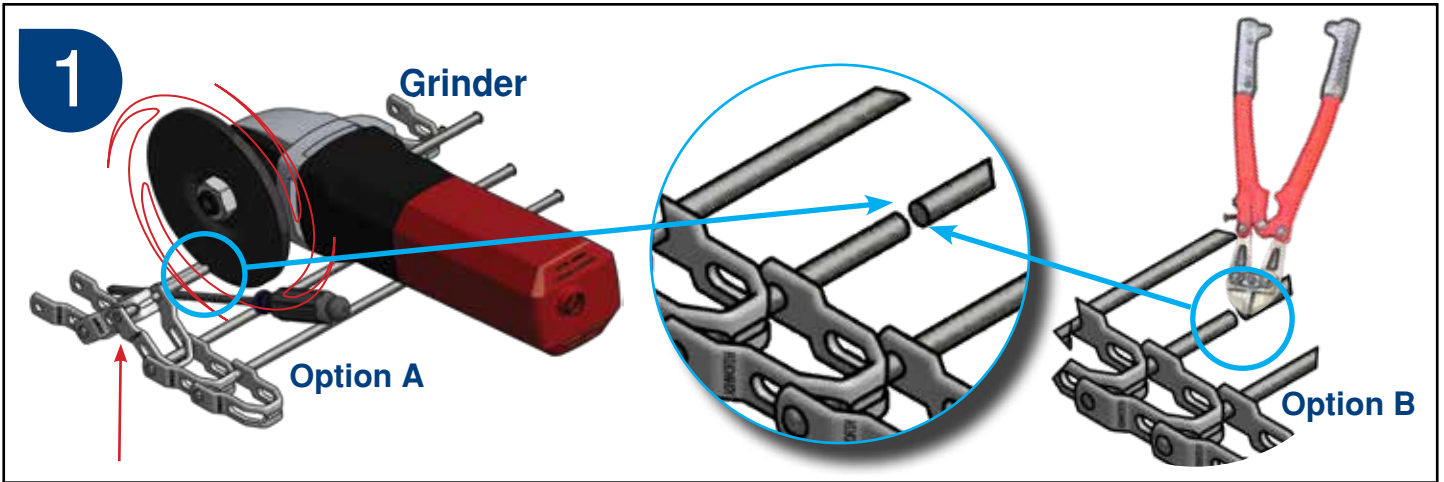

TIG Welder Amp Settings:

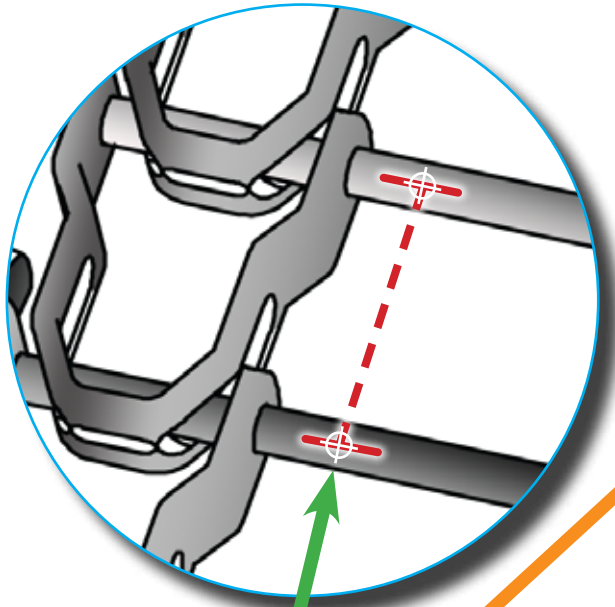

TIG Welder

⊕ — ⊕	Amps/DC
.75" = 19.1mm	60
1.00" = 27.4mm	60
1.20" = 30.5mm	80
1.50" = 38.1mm	80

Settings are approximate and may vary.
Shielding gas Ar. PROCEED WITH CAUTION.



Arc Welder

MIG Welder

Splicing in a New Rod:

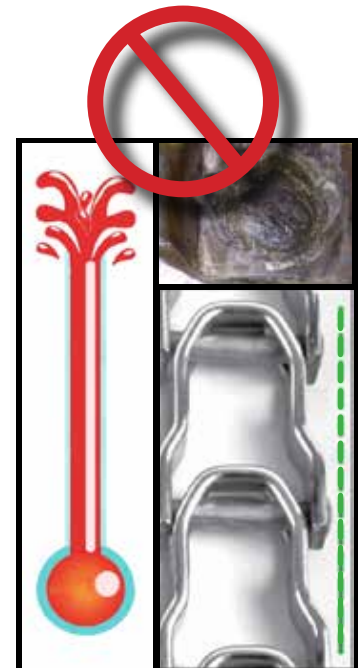
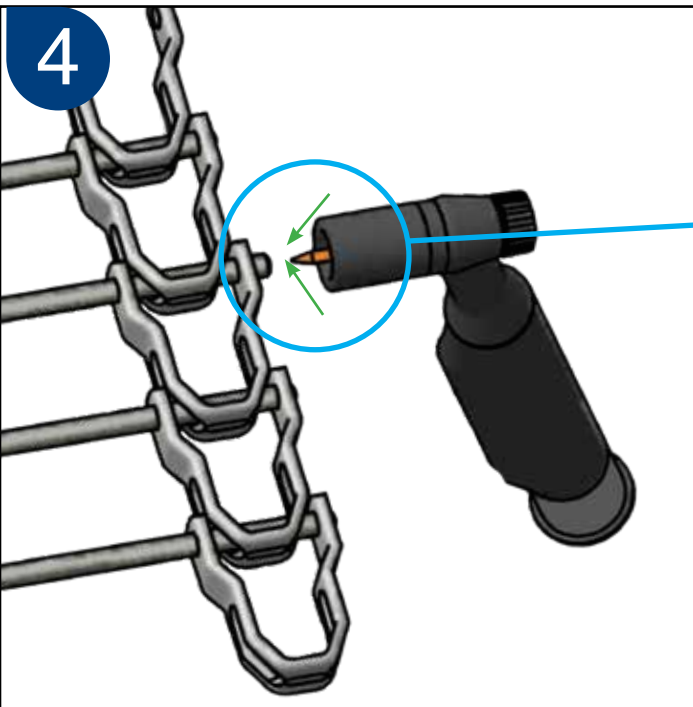
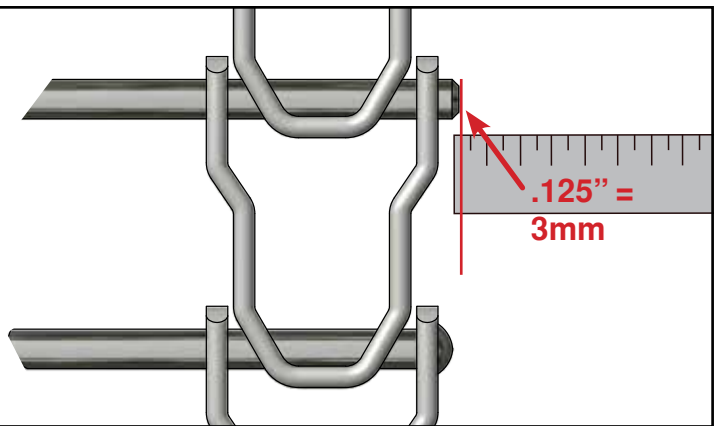
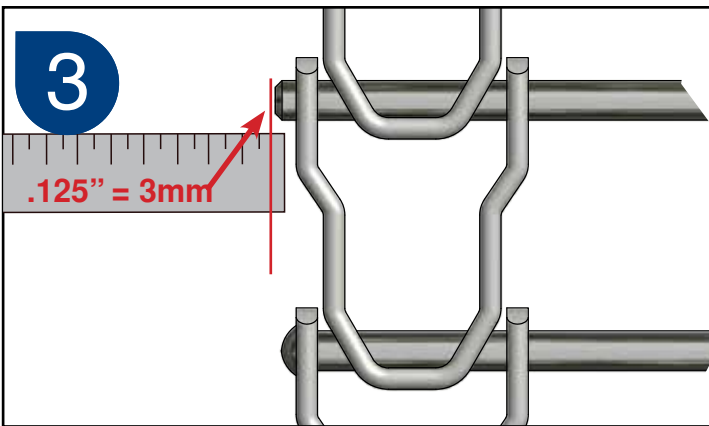
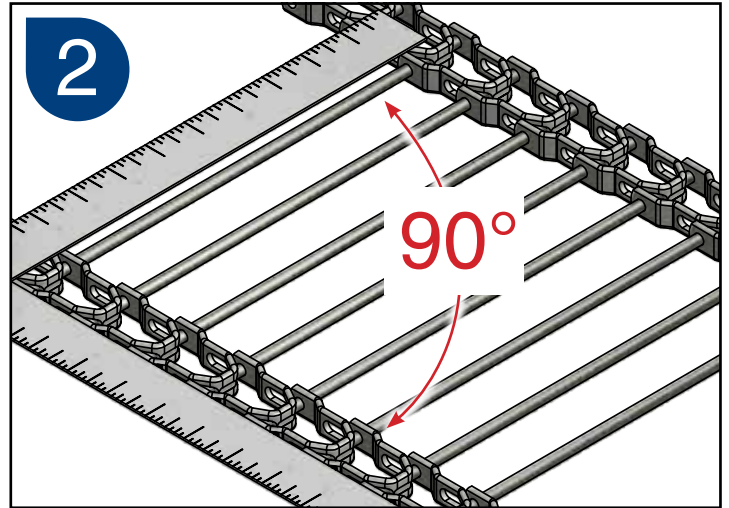
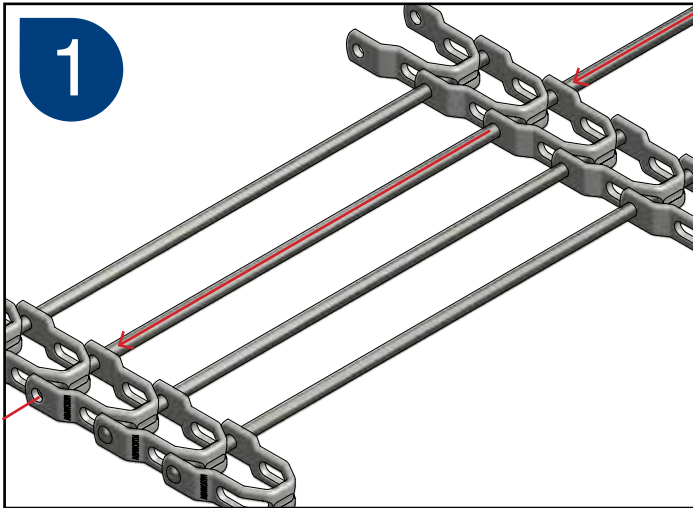

Ashworth Bros., Inc.
450 ARMOUR DALE, WINCHESTER, VA 22601
PHONE: 540-662-3494 OR 800-682-4594 FAX: 540-662-3150 OR 800-532-1730
www.ashworth.com