

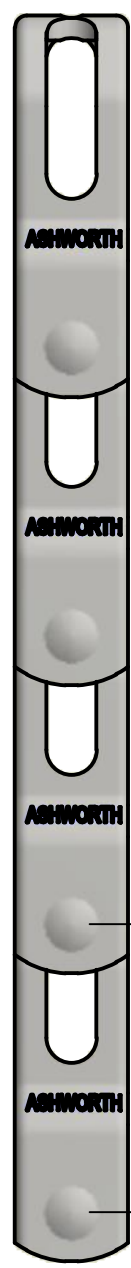

DWG NO.

SH  
1

REV  
A

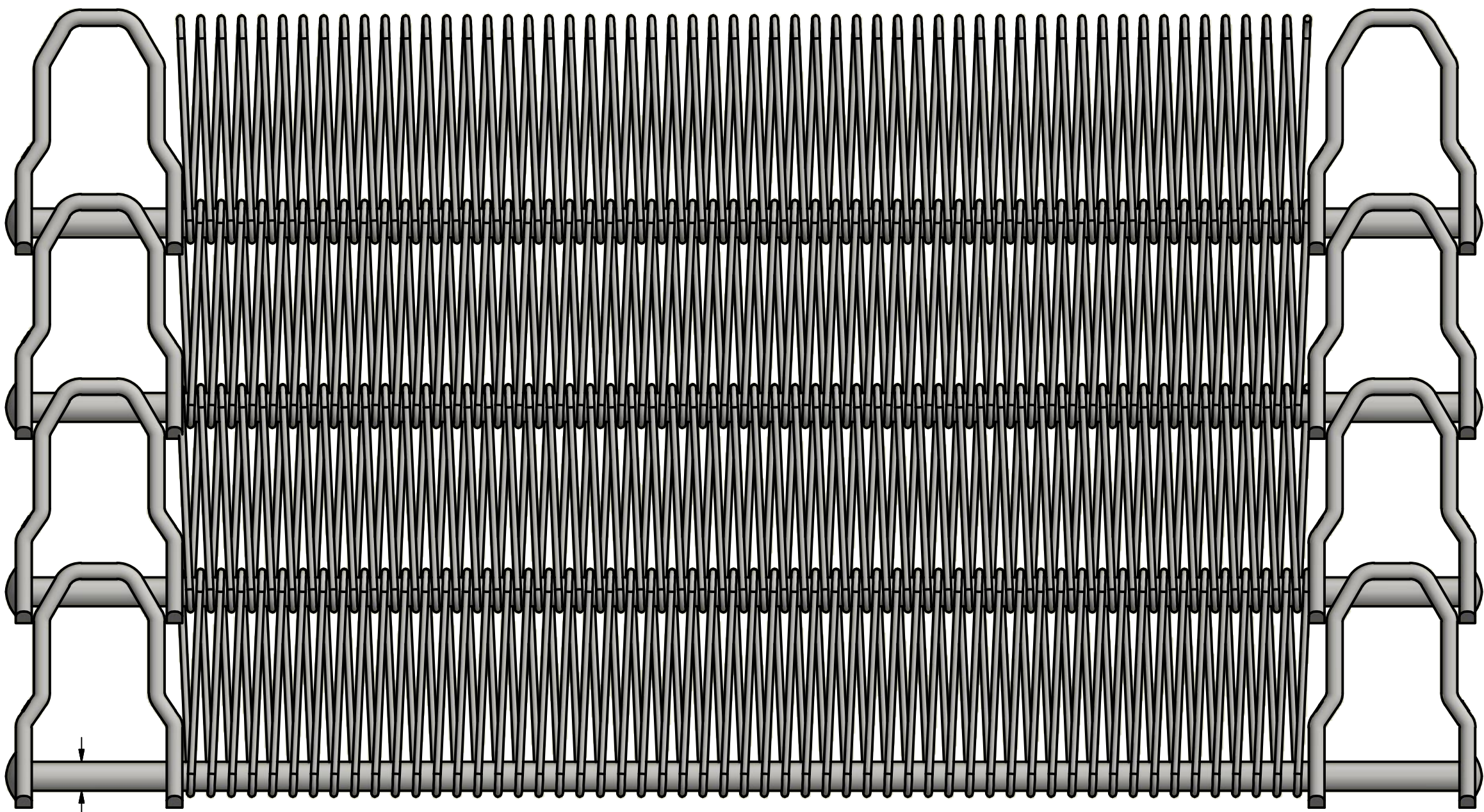

1.500 [38.10]  
BELT PITCH

Ø.236 [5.99]  
ROD

DO NOT SCALE DRAWING				<b>Ashworth Bros., Inc.</b> 450 ARMOUR DALE, WINCHESTER, VA 22601	
APPROVALS	DATE	TITLE			
DRAWN	7/8/16	ILLUSTRATION OG360-150 B72-8-17			
UNLESS OTHERWISE SPECIFIED DIMENSIONS ARE IN INCHES. TOLERANCES: .X = ± .03      FRACTION ± 1/16 .XX = ± .015     ANGLES ± 1/2° .XXX = ± .005 .XXXX = ± .0005   SURF FINISH 63 ✓		SIZE	DWG. NO.	REV.	
CAD/FILE NAME OP Assembly.idw		SCALE	CALC.WT	SHEET	
		1/1	N/A	1 OF 2	



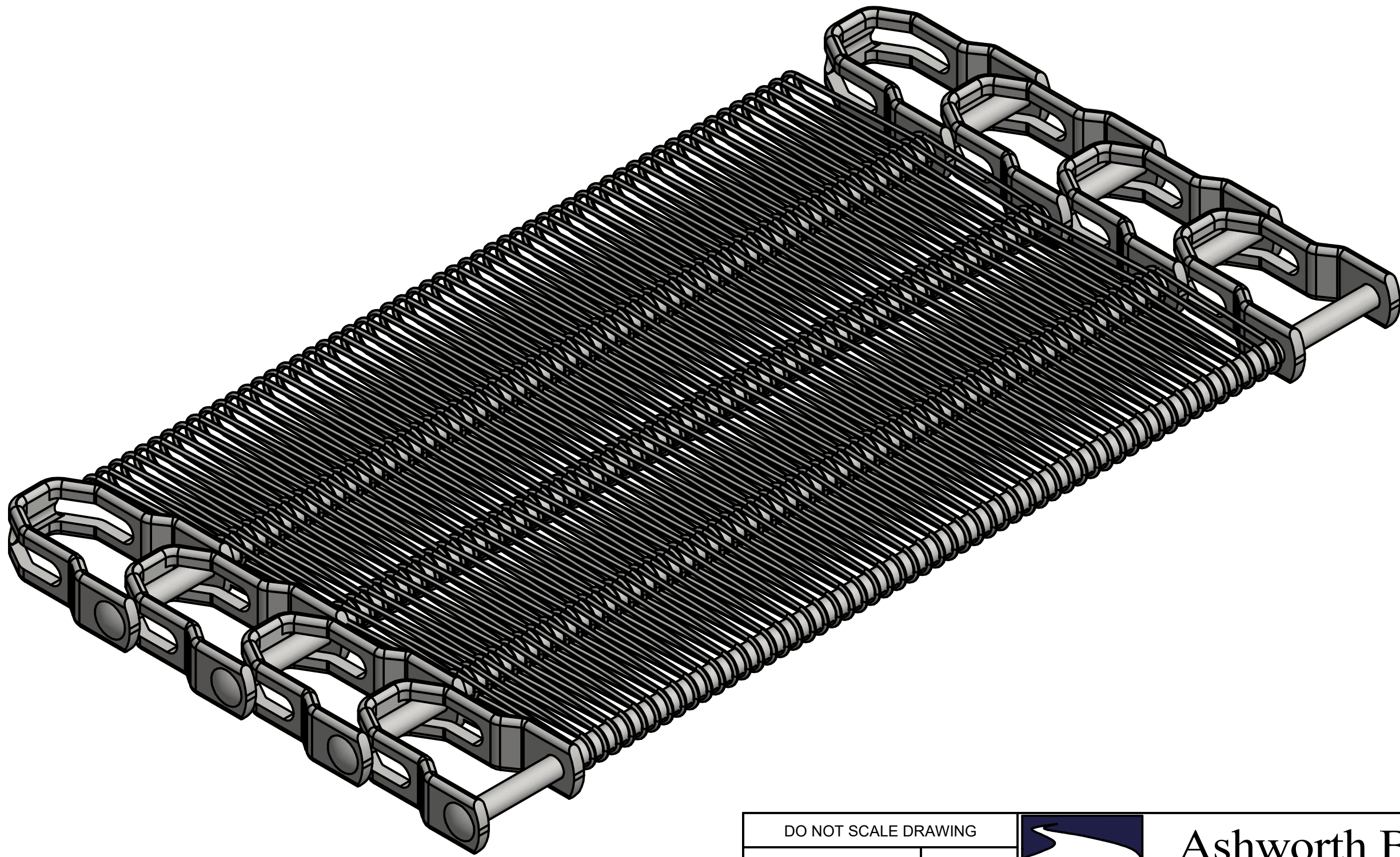

VIEW5  
SCALE 1/1

DO NOT SCALE DRAWING		 <b>Ashworth Bros., Inc.</b> 450 ARMOUR DALE, WINCHESTER, VA 22601
APPROVALS	DATE	
DRAWN	7/8/16	TITLE
UNLESS OTHERWISE SPECIFIED DIMENSIONS ARE IN INCHES. TOLERANCES: .X = ± .03      FRACTION ± 1/16 .XX = ± .015      ANGLES ± 1/2° .XXX = ± .005 .XXXX = ± .0005      SURF FINISH 63 ✓		ILLUSTRATION OG360-150 B72-8-17
SIZE	DWG. NO.	REV.
<b>B</b>		
CAD/FILE NAME	SCALE	CALC.WT
OP Assembly.idw	1/1	N/A
	SHEET	
	2 OF 2	