

REVISION HISTORY			
REV	DESCRIPTION	DATE	APPROVED
A		5/31/23	

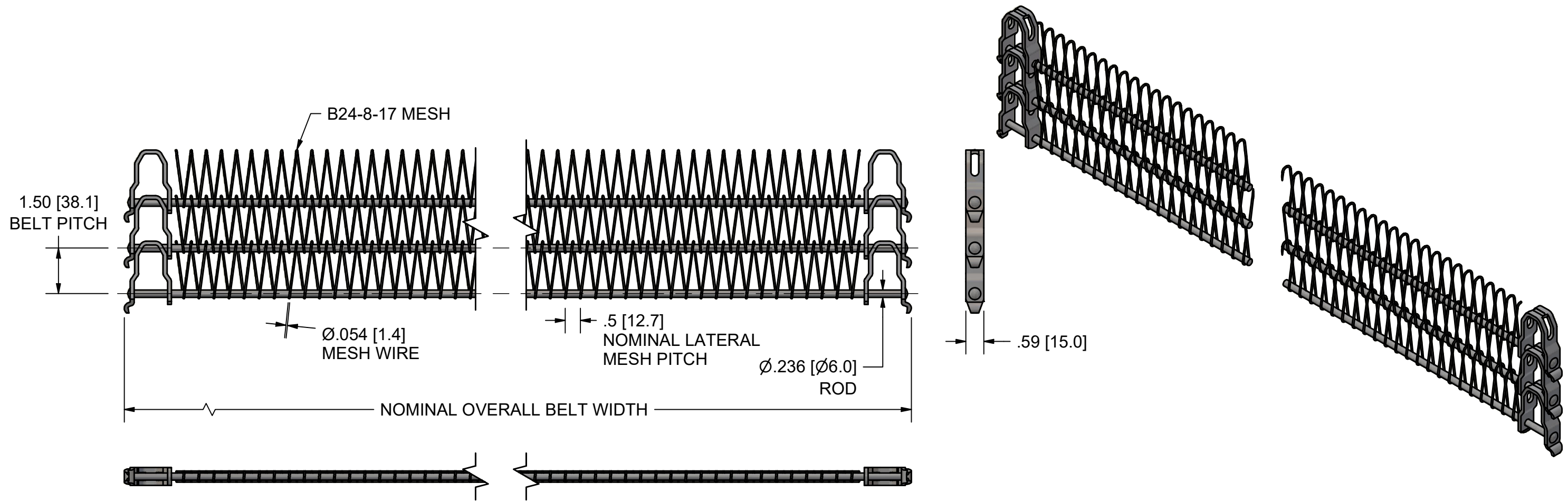

*PIGTAILS NOT SHOWN

THIS DRAWING CONTAINS CONFIDENTIAL INFORMATION AND TRADE SECRETS OF ASHWORTH BROS., INC. IT MAY NOT BE REPRODUCED IN WHOLE OR IN PART OR USED FOR THE BENEFIT OF ANYONE OTHER THAN ASHWORTH BROS., INC. NO RIGHT IS GRANTED TO DISCLOSE OR USE ANY INFORMATION SHOWN ON THIS DRAWING.

NOTES:

1. BELT: OP150: OMNI-PRO 150, B24-8-17 MESH OVERLAY
2. NOMINAL BELT WIDTH: PER ORDER
3. MATERIAL: PER ORDER

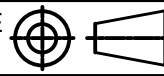
<small>UNLESS OTHERWISE SPECIFIED, DIMENSIONS ARE IN INCHES [mm]. DIMENSIONS NOTED ARE NOMINAL VALUES ONLY. ACTUAL DIMENSIONS ARE AFFECTED BY MANUFACTURING SPECIFICATIONS AND/OR PROCESS CONDITIONS. IF DETAILED DIMENSIONS ARE ESSENTIAL, CONTACT ABI ENGINEERING.</small>	CONTRACT / PROJECT NO.		 Ashworth Bros., Inc. <small>450 ARMOUR DALE, WINCHESTER, VA 22601</small>			
	APPROVALS	DATE	TITLE ILLUSTRATION, OP150, B24-8-17 MESH			
	DRAWN NEC	5/31/23				
	DESIGN NEC	5/31/23				
THIRD ANGLE PROJECTION 	CHECKED NEC	5/31/23	SIZE	CAGE CODE	ILLUSTRATION NO.	REV.
MATERIAL PER ORDER	REF ASSEMBLY		B	96664	OP150-B24-8-17	A
TREATMENT	REF PART		DO NOT SCALE	CALC.WT N/A	SHEET	1 OF 1
FINISH NONE	ASHWORTH PART NUMBER					

OP150-B24-8-17